

E-WM05-0000165AA

MOUNTING INSTRUCTION



IMPORTANT! READ THIS FIRST!

Installation of shock absorbers or other suspension components requires special tools and expert knowledge. Accordingly, installation of all BILSTEIN products must be performed by a professional automotive suspension technician.

When replacing other brands, BILSTEIN shock absorbers or other suspension components should always be installed as a set. All BILSTEIN products must only be used for the specific, intended application as indicated in the application guide. **Any use of any BILSTEIN product other than for its intended use may result in serious bodily injury or death.**

Always use a chassis hoist for the installation of BILSTEIN products and make certain that the raised vehicle is securely attached to the hoist and/or supported to prevent the vehicle from slipping, falling, or moving during the installation process.

If you install any BILSTEIN product without the necessary special tools, expertise, and chassis hoist, you may subject yourself to the risk of serious bodily injury or death.

BILSTEIN shock absorbers are gas-filled and are highly pressurized.

- Never place any BILSTEIN shock absorbers in a vise or use a clamp on any BILSTEIN shock absorber.
- Never apply heat near any BILSTEIN shock absorber.
- Never attempt to open or repair any BILSTEIN product, in order to prevent **serious bodily injury or death.**

Any attempt to misuse, misapply, modify, or tamper with any BILSTEIN suspension product voids any warranty and **may result in serious bodily injury or death.**

While installing any BILSTEIN product:

- Do not use impact tools for loosening or tightening fasteners, because this may destroy the screw threads.
- Self-locking fasteners must only be used **once!**
- Reuse original equipment components only if they are in good condition, otherwise replace them with new components.
- Never remove the slight film of oil on the shock absorber piston rod and seal.
- All mounting fasteners for shock absorbers and other suspension components must be securely tightened before tension is placed on the suspension system, unless otherwise specified in the manufacturer's service manual or in this instruction.

After installing any BILSTEIN product:

- The suspension caster and camber must be checked and/or adjusted to comply with the vehicle manufacturer's specifications.
- The (load dependent) brake compensator and the anti-lock brake system must be checked and/or reset to comply with the vehicle manufacturer's specifications.
- The headlight aim must be checked and adjusted. Or, if applicable, adaptive headlights must be checked and recalibrated to comply with the vehicle manufacturer's specifications.
- If applicable, any/all Advanced Driver Assistance Systems (ADAS) must be checked and recalibrated to comply with the vehicle manufacturer's specifications.

CAUTION for COILOVER TYPE SUSPENSIONS!!!

If disassembling a coilover type suspension, refer to the vehicle manufacturer's service manual for proper procedures. The coil spring is preloaded and must be compressed with a spring compressor to release load before the upper mount is disassembled. Failure to follow the vehicle manufacturer's procedures may cause serious injury or death and may damage the vehicle.

IMPORTANT!!!

This BILSTEIN product may or may not be compatible with non-BILSTEIN aftermarket products and/or vehicle modifications. It is the responsibility of the professional automotive suspension technician performing the installation to identify any non-OEM components and/or modifications on the vehicle that may interact with the suspension system. These must be evaluated for any potential physical static or dynamic interference with and/or effect on the function of this BILSTEIN product.

E-WM05-0000165AA MOUNTING INSTRUCTION



Bill of Materials (1 per shock)		
Item #	Part Description	Quantity
1	Locknut, M14x1.5	1
2	Spring Isolator	1

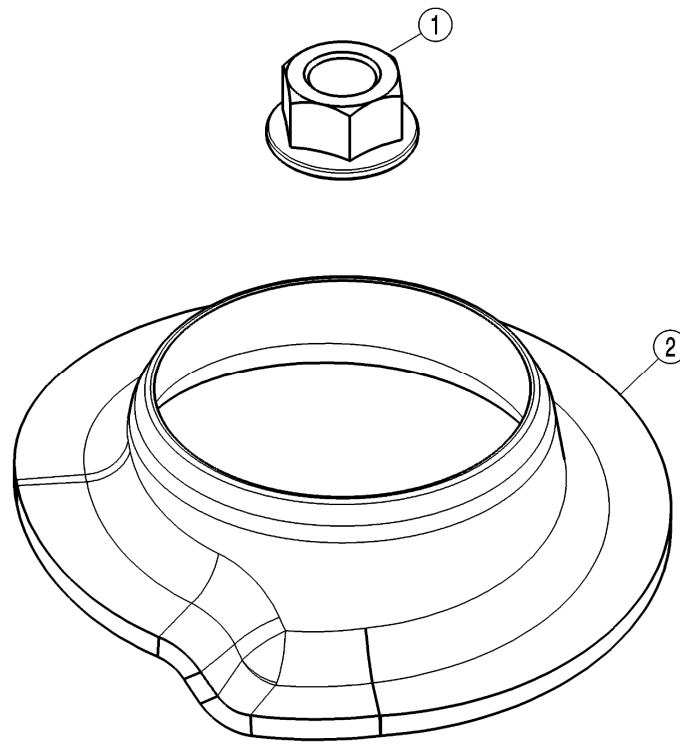

Figure 1

E-WM05-0000165AA MOUNTING INSTRUCTION



**IMPORTANT:
PLACE CIRCLIP IN APPROPRIATE GROOVE TO ADJUST RIDE HEIGHT.**

Use appropriate tools to move the circlip. Ensure that the circlip is fully seated in the groove after moving it (you should be able to rotate it manually in the groove). Install the spring seat in the direction shown only. The circlip must fit completely in the groove inside the spring seat (Detail A). **Improper installation will cause permanent damage to the shock!**

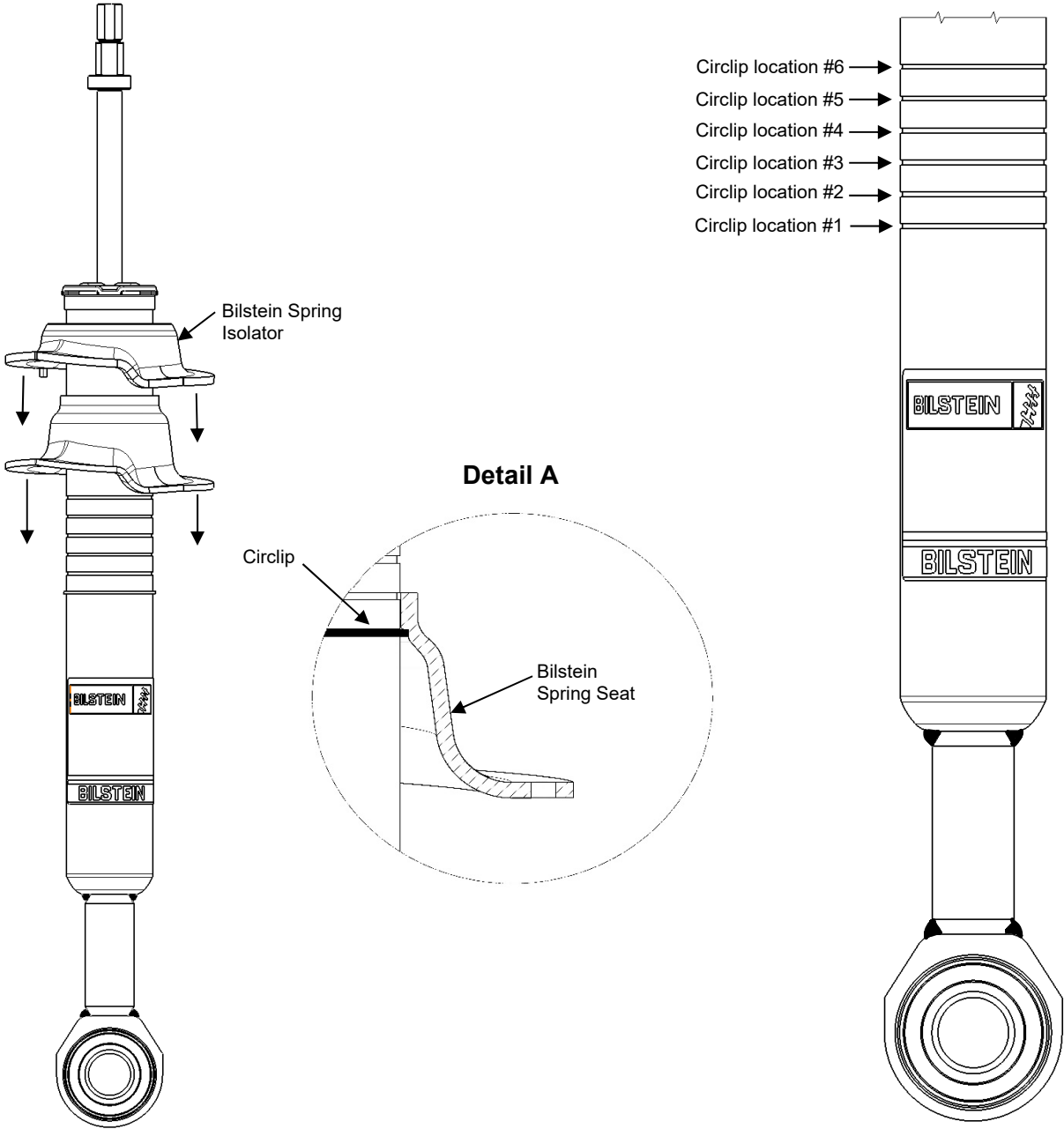

Figure 2 (B8 5100 is depicted)

E-WM05-0000165AA MOUNTING INSTRUCTION



B8 5100 Typical Lift Heights**	
Circlip Location (Both sides)	Land Cruiser 250 '24+ / 4Runner 4WD '25+ (all engines)
#6	2.75"
#5	2.2"
#4	1.65"
#3	1.1"
#2	0.55"
#1	Stock

** Lift heights indicated are typical. Actual lift height is influenced by which factory suspension the vehicle is equipped with and its condition; optional equipment and accessories on your vehicle, and other vehicle modifications such as replacement coil springs, wheel and tire combinations, etc. Modifying/lifting the suspension to your vehicle may raise its center of gravity and may make it more susceptible to loss of control and/or rollover, which may result in death or serious injury. We strongly recommend that you offset the loss of rollover resistance as much as possible by increasing tire track width. Wear seat belts at all times and avoid situations where a side rollover may occur.

Instructions for disassembly of OE shock absorber module:

- A. Remove the existing shock and spring unit from the vehicle following all procedures in the vehicle manufacturer's service manual.
- B. Note the clocking of the lower mount relative to the studs on the upper mount (important for reassembly).
- C. Also note the clocking of the coil spring relative to the OE upper mount. It is recommended to mark the OE upper mount and top coil to help indicate proper component alignment relative to the studs on the OE upper mount (important for reassembly). Refer to Figure 3.



Figure 3

- D. Using an appropriate spring compressor, compress the spring until it can be rotated freely by hand. Then, disassemble the shock and spring unit. Leave the OE jounce bumper inside the OE dust boot for re-use on the Bilstein shock.

E-WM05-0000165AA MOUNTING INSTRUCTION



Instructions for assembly of Bilstein B6 4600 or B8 5100 shock absorber module:

B6 4600: Skip steps E and F.

B8 5100: Skip steps E and F if using circlip location #1. If using circlip location #2-6, continue to step E. Trimming the OE dust boot is only necessary if circlip location #2-6 is being used.

- E. Trimming the OE dust boot is recommended to prevent damage to the boot. Remove the OE dust boot / jounce bumper from the OE upper mount.
- F. Using scissors, cut 73mm ($2\frac{7}{8}$ ") from the bottom of the boot. Refer to Figure 4 below.

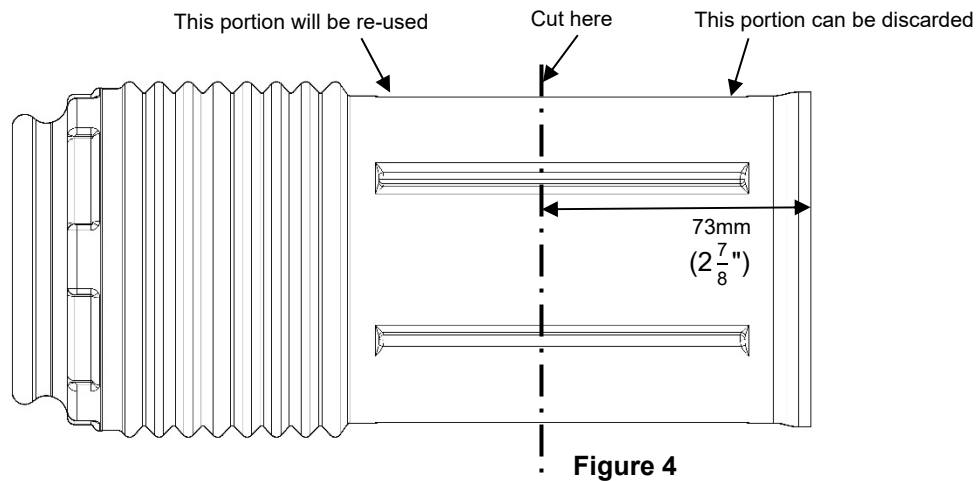

[Refer to Figure 2 on page 3 for steps G-I]

- G. Select desired lift height by seating the circlip in the appropriate circlip location (**B8 5100 only**).
- H. Install the supplied spring seat on to the circlip such that the groove inside the spring seat fits over the circlip on the shock body as shown. The circlip must fit completely in the groove inside spring seat (see DETAIL A). *Improper installation will cause permanent damage to the shock.*
- I. Install the supplied spring isolator (BOM Item 2) on to the new Bilstein shock and on to the spring seat in the direction shown only.

[Refer to Figure 5 on page 7 for steps J-M]

- J. Using an appropriate spring compressor, compress the OE spring and assemble it with the new Bilstein shock.
- K. Install the OE upper mount and rotate the OE spring until the mark made on the top coil is aligned with the mark made on the OE upper mount as shown in Step C (Figure 3).
- L. Rotate the shock so the lower mount is aligned with the upper mount studs as noted in step B. Rotate the supplied spring seat / isolator so they're indexed with the end of the bottom coil.
- M. Install the supplied locknut (BOM Item 1) and tighten to 65 Nm (48 lb·ft).

******DO NOT USE AN IMPACT WRENCH TO TIGHTEN THE LOCKNUT!******

E-WM05-0000165AA

MOUNTING INSTRUCTION



- N. Slowly release the spring compressor while ensuring that everything mentioned in steps K and L remain aligned.
- O. Install the assembly on to the vehicle and tighten all fasteners to vehicle manufacturer's specifications. Be sure to lower the vehicle such that its full weight is on the suspension prior to fully tightening the lower shock bolt.
- P. Check wheel alignment. If necessary, adjust to the vehicle manufacturer's specifications. This completes the installation.

E-WM05-0000165AA MOUNTING INSTRUCTION

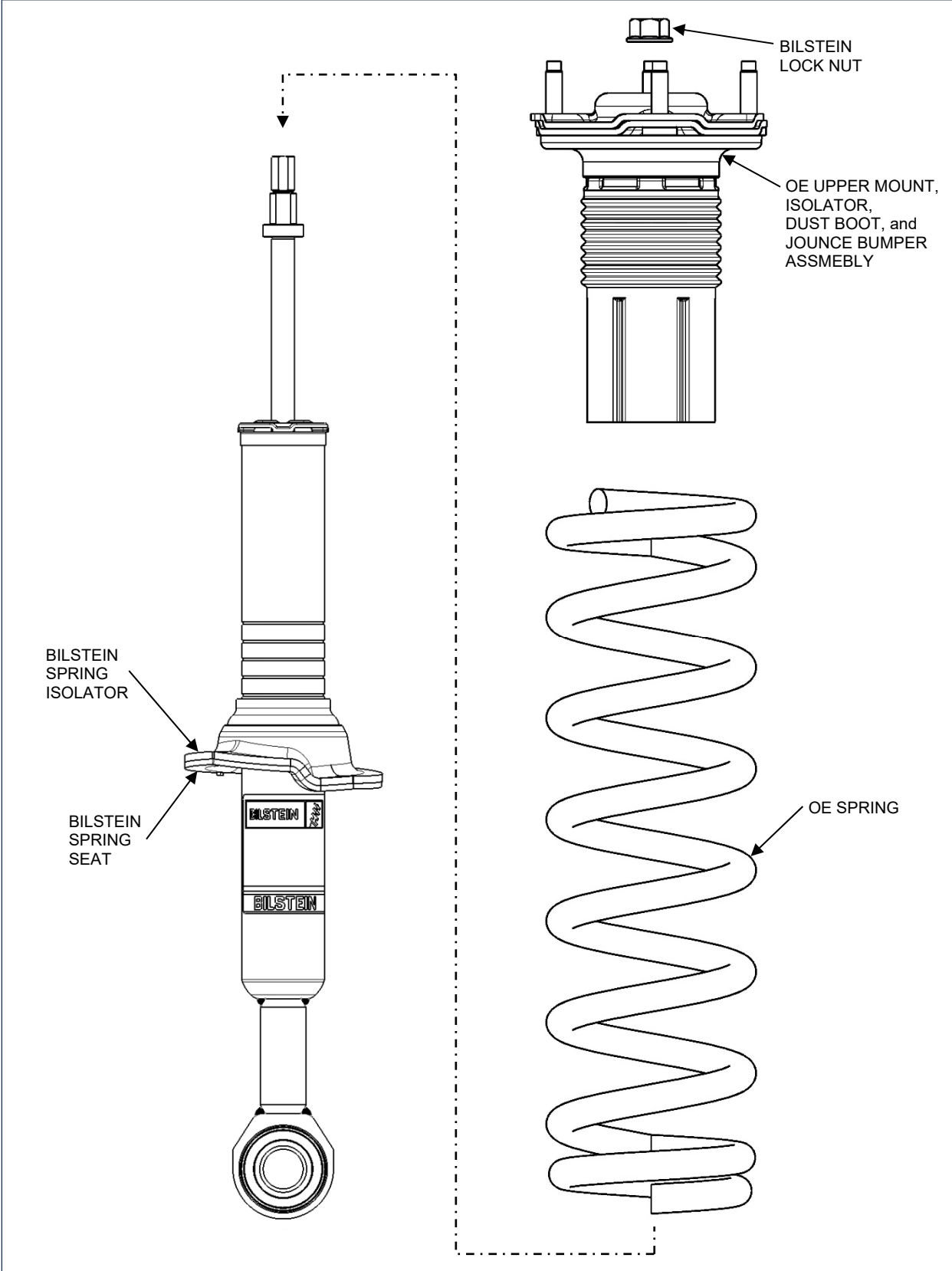

Figure 5